

Computational Fluid Dynamics Evaluation of an Oil-flooded Screw Compressor

Ion Malael

National Research and Development Institute for Gas Turbines COMOTI, Romania
ion.malael@comoti.ro (corresponding author)

Valentin Petrescu

National Research and Development Institute for Gas Turbines COMOTI, Romania | University Politehnica of Bucharest, Romania
valentin.petrescu@comoti.ro

Received: 15 June 2023 | Revised: 27 June 2023 | Accepted: 7 July 2023

Licensed under a CC-BY 4.0 license | Copyright (c) by the authors | DOI: <https://doi.org/10.48084/etasr.6122>

ABSTRACT

The cost of energy is directly influenced by geopolitical, economic, and environmental factors. There is an international trend towards renewable resources, although the implementation pace and legislation in force have issues. Complete abolishment of fossil fuels is practically impossible. Evolution is only possible with the use of these fuels but with modern, efficient equipment to reduce the pollution resulting from the process of extracting, processing, and using fossil fuels. In this paper, a screw compressor with oil injection, used in oil extraction stations, is analyzed numerically. This analysis is useful in the process of modernizing and improving the efficiency of this type of compressor, which is capable of operating in extreme working regimes, highly contaminated with impurities. The numerical analysis presented certain challenges related to biphasic flow in extremely small spaces at high compression ratios. The results include the absolute pressure variation and the flow rate variation. Regarding future research, test series will be carried out to validate the numerical results on the test bench with a 1:1 scale prototype.

Keywords-screw compressor; multiphase flow; CFD; volumetric efficiency

I. INTRODUCTION

Screw compressors are compact, volumetric rotary devices with a few moving parts that function efficiently over a wide range of speeds and pressures [1]. Their application in many areas is relatively new. Compressors with two rotors ("male" and "female," or leading rotor and driven rotor) were invented in 1955 [2], while single-rotor compressors were presented in 1971 [3]. As a result, there are only a few providers globally, and INCDT COMOTI is the sole unit in Romania that investigates and produces such equipment [4]. The volume index (V_i) and the form of the rotors are the two most important structural components on which the compression process is dependent. The rotor geometry of the most popular screw compressors is based on the Sveridge Rotor Maskiner (SRM) license, with a "male" rotor with four lobes and a "female" rotor with six channels [5]. These compressors' flow rate is governed by the rotor diameter and length, as well as speed. After the '80s, the profiles known as Sigma were created, resulting in rotor diameters as small as 100 mm and speeds as high as 2950 rpm [6]. The appropriate peripheral speed is 50 m/s for SRM rotors and 15-20 m/s for Sigma rotors. The diameter D of the rotor and the ratio between the length L and the diameter of the rotors are the defining dimensions for these volumetric machines [7]. V_i describes the geometry of each individual compressor, and the maximum yield η_{max} is

attained when $\pi_c = V_i^k$, where π_c is the compression ratio and k is the adiabatic index value dependent on the nature of the working agent [8]. There are the following recommendations:

- $V_i=2.5$ for air conditioning and heat pumps ($\pi_c \approx 5$)
- $V_i=3.5$ for cooling processes ($\pi_c \approx 8$)
- $V_i=5$ for freezing at low temperatures ($\pi_c \approx 15$)

Screw compressors are high-efficiency devices that compress various working fluids used in industry. A screw compressor's working chamber is formed between the rotors' lobes sections and the casing, which shrinks as the rotors revolve, carrying out the compression process [9]. Figure 1 depicts a Computer-Aided Design (CAD) model of a screw compressor. Clearances between the rotors and between the rotors and the casing must be kept to a minimum for optimal compression. To ensure thermal expansion, these clearances for compressors with oil injection can be on the order of 40 μm , and for those without injection, they can be of the order of 100 μm [10].

In the research and development of new innovative products [11] that can be introduced to the market, the use of numerical approaches in the design process has come to represent a particularly significant step [12]. Computational

Fluid Dynamics (CFD) approaches have recently been extensively employed to assess the performance of a volumetric machine with positive displacement. The use of finite volume techniques entails meshing the computational domain for the unsteady, three-dimensional modeling of flow through a screw compressor [13-14]. Even though the concept of a screw compressor is relatively new, studies on the thermodynamics of screw compressors have been conducted with the goal of developing a mathematical model. These models were used to both analyze and optimize the profiles of the rotor lobes [15-17]. The performance of such a machine may be predicted using CFD techniques. These approaches are used in the study of flow in screw compressors to investigate unstable flows with shifting boundaries.

Authors in [18] investigated the flow into the screw compressors with similar limits. A particularly critical issue occurs when utilizing finite volume techniques to examine the flow through screw compressors, especially the formation of the computation grid for unsteady simulations with grid motions. The calculating grid must deform in the same way that the volumes in the compressor vary with the rotation of the rotors. It has been shown [19, 20] that no commercial grid generation software is currently capable of achieving this. Despite this, only a few reports of unsteady flow in 3D for screw compressors with large discharge pressures [21-22] have been published.

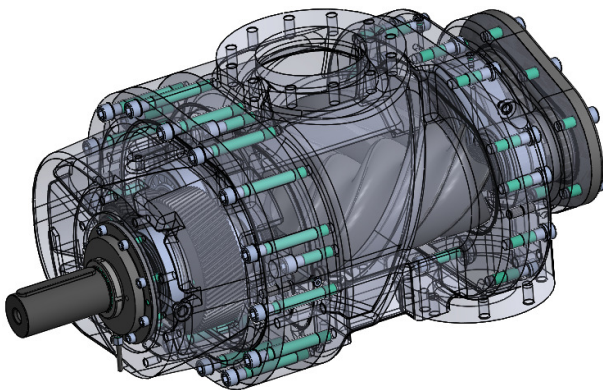

Fig. 1. 3D CAD screw compressor model.

The numerical complexity of multiphase flow (gas and oil) via small gaps on the order of tens of microns [23] is also carried to the following components of a screw compressor compression station [24]. As a result, the process of separating gas from oil becomes a separate issue that requires specific attention [25]. This may be accomplished by employing separators with porous material filters [26], capable of retaining oil droplets as small as 0.1 microns [27]. An oil-injected screw compressor with a compression ratio larger than 9 in a single stage was mathematically investigated in this paper. The generation of the calculation grid for the rotor domain [28], the setting of the multiphase case [29], and the stabilization of the solver by using an initialization file [30] in which the flow through a screw compressor without oil injection was analyzed were among the challenges of this analysis.

II. GRID GENERATION

Using a combination of structured and unstructured meshes, the working domain of a screw compressor may be discretized. The rotor domain, the pressure domain, and the suction domain are each represented by one of the three subdomains of the flow domain. The whole grid of a screw compressor can be seen in Figure 2. Grids that combine structured and unstructured elements can be used to discretize stator domains. But in order to create the computation grid for the rotor domain, specialized software is required. TwinMesh [29] is specifically designed for positive displacement machines with two rotors that are arranged in parallel planes and have complicated geometries. The common IGES format or a CSV-type file is used for the geometry input. Two meshed rotors with O-grid grids that are joined via an interface make up the typical topology. Such a topology is seen in Figure 3.

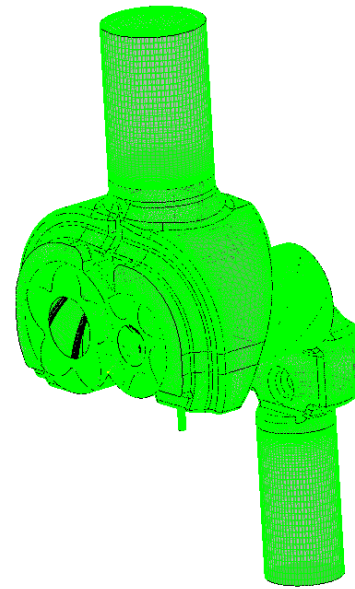

Fig. 2. Screw compressor mesh.

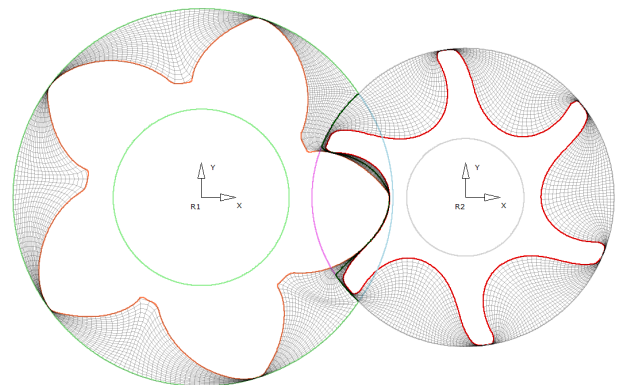

Fig. 3. TwinMesh-based 2d computational grid topology.

With the rotor and casing curves imported, the TwinMesh program creates 2D meshes for various rotor locations. The software builds an interface between the two rotors and initializes an O-grid for each rotor for each 2D grid [30].

Explicit and iterative techniques are used to smooth out the original grids. These techniques are based on standards such as the uniform distribution of nodes on the border, the growth ratio of the elements, the element's minimum angle, etc. [31]. The user defines the number of elements, which is directly influenced by the node distribution throughout the geometry. Figure 4 displays the grid's quality, with the red parts denoting the lower-quality components.

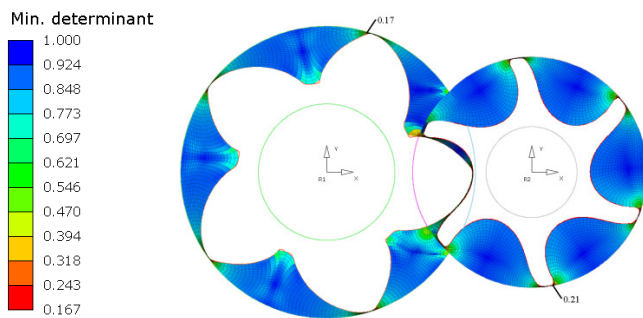

Fig. 4. Mesh quality.

For all 2D grids related to rotation angles, the quality of the computation grid may be checked (minimum angle, determinant, growth rate, change of volumes, etc.). The 3D grid is created with improved resolution when all 2D grids have been finished. In general, the criteria for evaluating the quality of calculation grids for volumetric machines with positive displacement [32] are based on the following:

- the grid must accurately represent the fluid domain
- the internal angle must be greater than 18° and the element distribution must be uniform
- small changes in the position of the nodes for two consecutive angles
- the number of grids per rotation must be adequate, preferably from degree to degree

Since all 3D grids have the same grid topology and number of nodes, the CFD solver can handle deformed grids without interpolation by applying just conservation rules. The number of elements and their types for each subdomain are shown in Table I.

TABLE I. MESH STATISTICS

No.	Subdomain	No. of nodes	No. of elements		
			Tetrahedral	Pyramid	Hexahedral
1.	Rotor	2223350	-	-	2097120
2.	Suction	438460	1792222	1805	88445
3.	Discharge	197161	534856	1805	88445
4.	Injection pipe	89300	-	-	85652
5.	TOTAL	2948271	4690350		

III. CFD ANALYSIS

The choice of the ANSYS CFX software for the modeling of such a complicated flow was made due to the wide variety of numerical models at its disposal. The following parameters are used with volumetric machines:

- Grid deformation: since the grid movement is taken into account by the differential equations, interpolation is not required. Instead, FORTRAN code is used to read the grids from TwinMesh and calculate the movement.
- The complex properties of working fluids, such as non-Newtonian fluids or fluids with high viscosity, ideal or real gas models, etc.
- The multi-phase models, such as the water or oil injection in screw compressors.
- The heat transfer model, i.e. the thermal transfer from fluid to solid and vice versa.
- The turbulence models, such as the Reynolds-Averaged Navier-Stokes models and scale-resolving models.

The description of the rotor movement, the definition of the suction domain, the discharge domain, along with the oil inlet ports, and the definition of the interfaces between the domains all come first when setting up the case for simulating the flow through a screw compressor. Figure 5 shows the geometry of the CLP180-type rotors employed in these simulations, with five "male" lobes and six "female" lobes. The rotors have a 412.45 mm length, a 180 mm space between their two axes, and rotate at 3343 rpm for "male". The distance between the rotors is approximately 20 μm, while the distance between the rotors and the housing is around 50 μm.

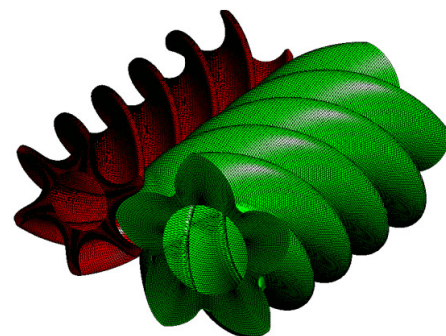

Fig. 5. Rotors shapes with surface mesh.

The oil used was TURBIN YAGI 68, whose physical projections (molar mass, density, specific heat capacity, reference temperature, reference pressure, reference specific enthalpy, reference specific entropy, dynamic viscosity, and thermal conductivity) were established experimentally [33]. The working fluid was selected as ideal gas air, and the turbulence model used was the SST (Shear-Stress Transport). The time step for the unsteady analysis was determined by the speed of the screw compressor. Figure 6 depicts the boundary constraints that ANSYS CFX Pre imposes in order to make the mathematical approach as realistic as possible. At the inlet and outlet, where the pressure was applied (1 bar for the inlet and 9 bars for the outflow), "opening" conditions are therefore mandated. For the oil port inlet condition volume II's pressure (2.5 bar) was enforced. In order to assess the pressure in the four volumes that develop at the start of the compression process, four monitoring points were created for real-time monitoring. These dots can be seen in Figure 6 (right).

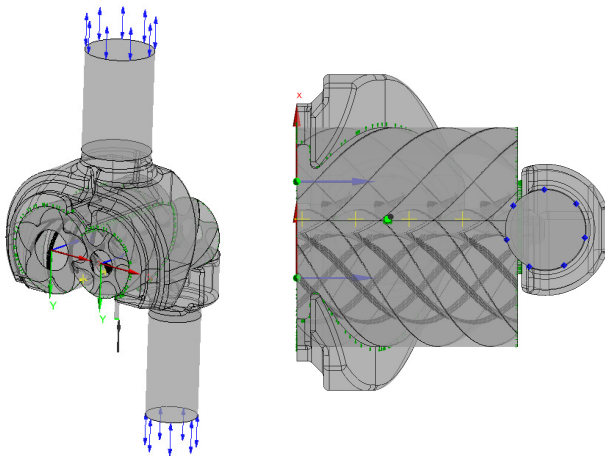

Fig. 6. Ansys CFX Pre boundary conditions.

IV. SIMULATION RESULTS

This analysis's goal is to ascertain how oil injection impacts a screw compressor's performance. This led to the analysis of a compressor with an intake pressure of 1 bar and a discharge pressure of 9 bars. The distributions of pressures and speeds in certain planes, as well as changes in flow and pressure at the compressor's intake and exit, are depicted in Figures 7-8.

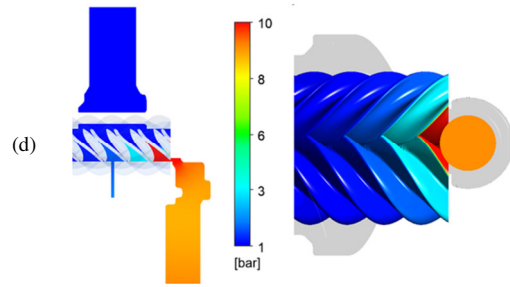

Fig. 7. Absolute pressure location: (a) 0, (b) 18, (c) 36, and (d) 54 degrees.

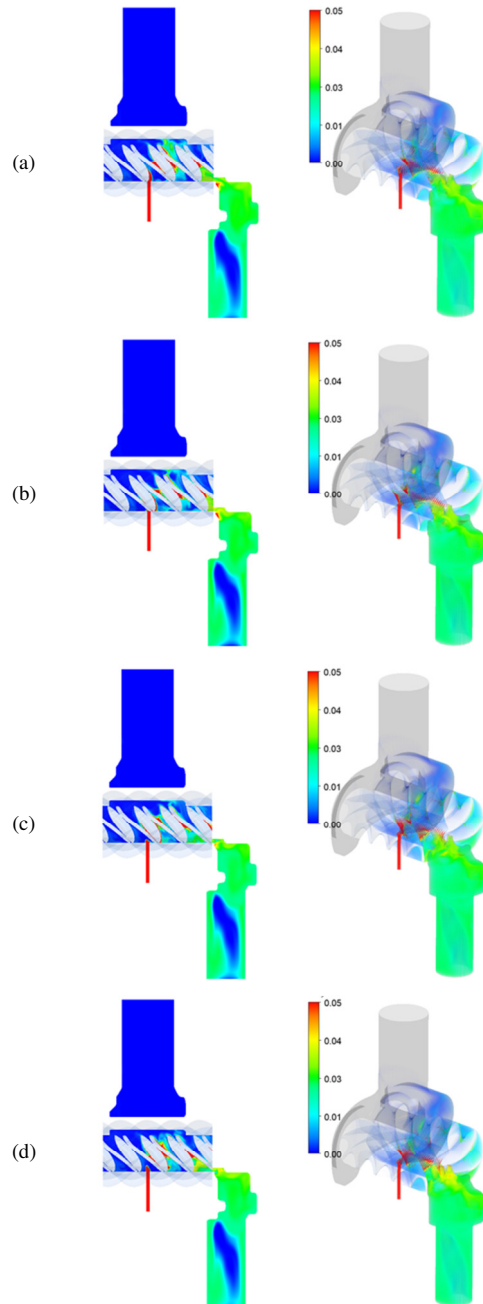
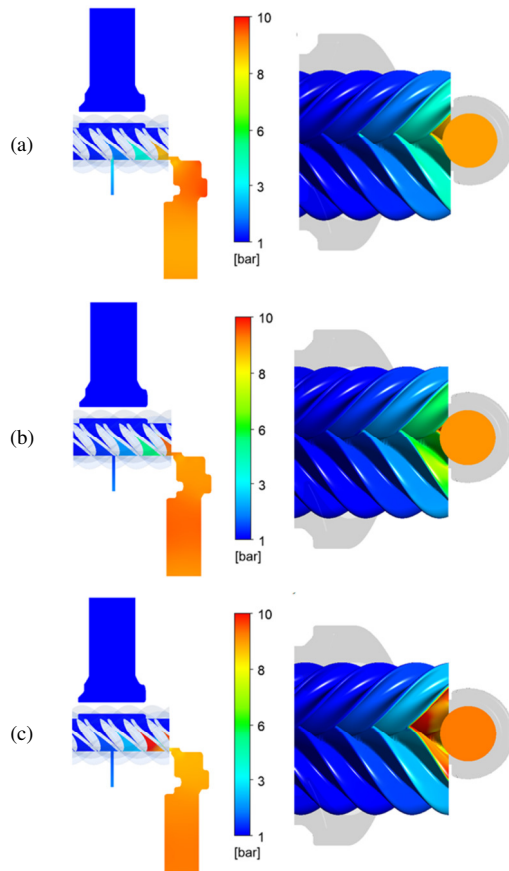

Fig. 8. Oil volume fraction: (a) 0, (b) 18, (c) 36, and (d) 54 degrees.

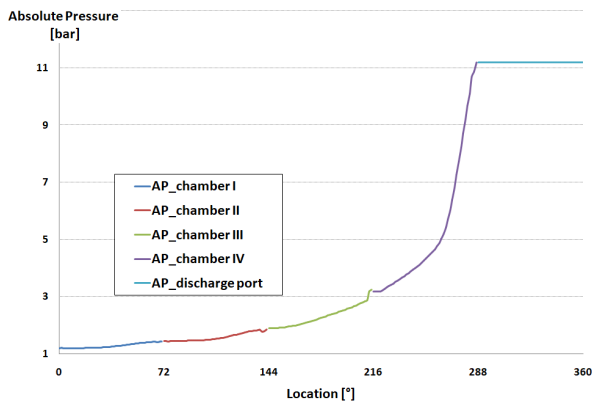

Fig. 9. Absolute pressure evolution through all four chambers.

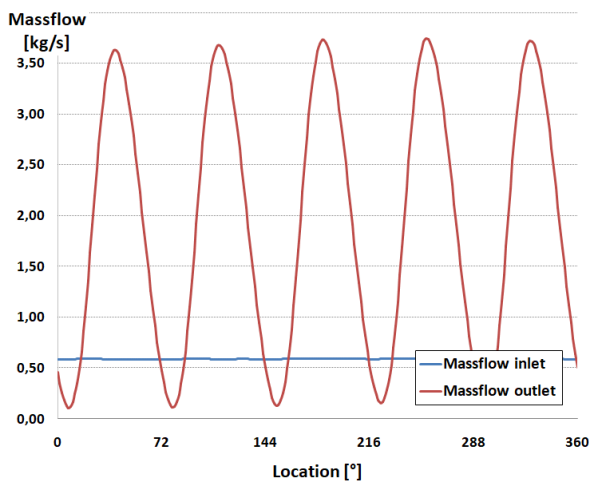

Fig. 10. Mass flow variation per one complete revolution.

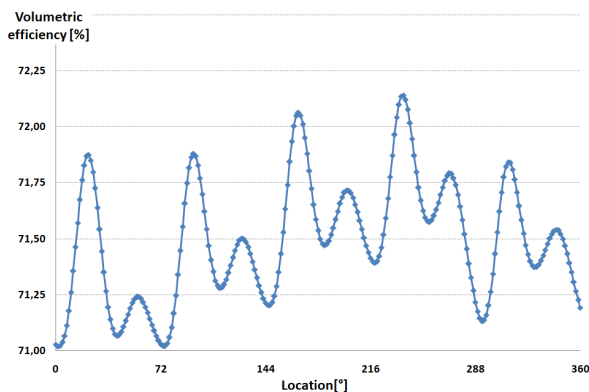

Fig. 11. Volumetric efficiency.

V. CONCLUSIONS

Numerous challenges arise when analyzing multiphase flows when they are conducted in extremely tiny areas, especially in the scale of microns. For several geometrical and physical features that the volumetric machine, the screw compressor with oil injection, exhibits, it is challenging to develop hypotheses regarding the numerical analysis.

In this paper, the challenge is doubled by the fact that we are dealing with a high pressure ratio, 9, in a single stage. The flow was examined using TwinMesh grid generation software, and the flow's underlying equation system was solved using Ansys CFX. As a result, real-time monitoring of the absolute pressure in each of the four volumes was produced when the compression process began. The fluctuation of the absolute pressure and the flow rate from the compressor's intake to its exit are among the findings. Also, the volumetric efficiency was determined numerically, and for pressure ratio equal to 9, was 71%. The numerical analysis is a crucial step in the creation of new screw compressors since it reveals significant data about their efficiency.

The originality of this work lies in the numerical modeling of an oil-injected screw compressor that can achieve a compression ratio larger than 9 in a single step. Unfortunately, most studies terminate at pressure ratios of up to 3–4 due to the solver's instability. To the best of our knowledge, there are no studies that mention such flows (biphase with significant pressure gradients). Due to this, in the future research, experimental testing series will be carried out to validate the numerical results. These tests will be carried out on the testing facility [34] for screw compressors that the Romanian Research and Development Institute for Gas Turbines (COMOTI has. The setup is shown in Figure 12.



Fig. 12. Experimental testing facility.

ACKNOWLEDGMENT

This work was carried out within the "Nucleu" Program EvoTurbo 2023, and is supported by the Romanian Minister of Research, Innovation and Digitalization, under project number PN23.12.05.01.

REFERENCES

- [1] W. Wu and Z. Zhang, "Development of single screw compressor technologies and their tendency," *Proceedings of the Institution of Mechanical Engineers, Part E: Journal of Process Mechanical Engineering*, vol. 236, no. 2, pp. 738–751, Apr. 2022, <https://doi.org/10.1177/09544089211043011>.
- [2] N. Stošić, "Review Article: Screw Compressors in Refrigeration and Air Conditioning," *HVAC&R Research*, vol. 10, no. 3, pp. 233–263, Jul. 2004, <https://doi.org/10.1080/10789669.2004.10391102>.

- [3] F. L. Yuditskii, B. L. Grinpress, and Yu. L. Semenov, "Dismountable end face seal for screw compressors," *Chemical and Petroleum Engineering*, vol. 7, no. 2, pp. 167–168, Feb. 1971, <https://doi.org/10.1007/BF01146549>.
- [4] M. Nitulescu *et al.*, "New projects developed by COMOTI in gas industry," *IOP Conference Series: Materials Science and Engineering*, vol. 90, no. 1, Apr. 2015, Art. no. 012015, <https://doi.org/10.1088/1757-899X/90/1/012015>.
- [5] M. Chamoun, R. Rulliere, P. Haberschill, and J.-L. Peureux, "Modelica-based modeling and simulation of a twin screw compressor for heat pump applications," *Applied Thermal Engineering*, vol. 58, no. 1, pp. 479–489, Sep. 2013, <https://doi.org/10.1016/j.applthermaleng.2013.04.020>.
- [6] D. Hairston, "Rotary screw compressors reduce energy consumption. (Focus on: fans, blowers & compressors)," *Chemical Engineering*, vol. 109, no. 12, pp. 39–40, Nov. 2002.
- [7] T. N. Mustafin, R. R. Yakupova, A. V. Burmistrova, M. S. Khamidullina, and I. G. Khisameeva, "Analysis of Influence of Screw Compressor Construction Parameters and Working Condition on Rotor Temperature Fields," *Procedia Engineering*, vol. 152, pp. 423–433, Jan. 2016, <https://doi.org/10.1016/j.proeng.2016.07.612>.
- [8] P. Harnatkiewicz, E. Rusinski, and P. Moczko, "The lifetime prediction of a rotary screw compressor of a liquid cooler subjected to high pressure and high frequency loads," *Engineering Failure Analysis*, vol. 17, no. 6, pp. 1290–1299, Sep. 2010, <https://doi.org/10.1016/j.engfailanal.2010.03.003>.
- [9] J. Li, H. Wu, B. Wang, Z. Xing, and P. Shu, "Research on the performance of water-injection twin screw compressor," *Applied Thermal Engineering*, vol. 29, no. 16, pp. 3401–3408, Nov. 2009, <https://doi.org/10.1016/j.applthermaleng.2009.05.018>.
- [10] T. Tam *et al.*, "Experimental Investigation of Screw Compressor Clearance Monitoring Techniques," in *26th International Compressor Engineering Conference at Purdue*, Jul. 2022, Art. no. 1136.
- [11] P. Salami, Y. Ajabshirchi, S. Abdollahpoor, and H. Behfar, "A Comparison Among Different Parameters for the Design of a Photovoltaic/Thermal System Using Computational Fluid Dynamics," *Engineering, Technology & Applied Science Research*, vol. 6, no. 5, pp. 1119–1123, Oct. 2016, <https://doi.org/10.48084/etasr.667>.
- [12] A. C. Mangra, "Design and Numerical Analysis of a Micro Gas Turbine Combustion Chamber," *Engineering, Technology & Applied Science Research*, vol. 10, no. 6, pp. 6422–6426, Dec. 2020, <https://doi.org/10.48084/etasr.3835>.
- [13] A. Spille-Kohoff, J. Hesse, and A. E. Shorbagy, "CFD simulation of a screw compressor including leakage flows and rotor heating," *IOP Conference Series: Materials Science and Engineering*, vol. 90, no. 1, Apr. 2015, Art. no. 012009, <https://doi.org/10.1088/1757-899X/90/1/012009>.
- [14] H. Ding and Y. Jiang, "CFD simulation of a screw compressor with oil injection," *IOP Conference Series: Materials Science and Engineering*, vol. 232, no. 1, Dec. 2017, Art. no. 012020, <https://doi.org/10.1088/1757-899X/232/1/012020>.
- [15] T. W. Bein and J. F. Hamilton, "Computer Modeling of an Oil Flooded Single Screw Air Compressor," in *International Compressor Engineering Conference*, 1982, Art. no. 383.
- [16] W. W. Boblitt and J. Moore, "Computer Modeling of Single-Screw Oil Flooded Refrigerant Compressors," in *International Compressor Engineering Conference*, 1984, Art. no. 506.
- [17] W. Jianhua and J. Guangxi, "The Computer Simulation of Oil-Flooded Single Screw Compressors," *International Compressor Engineering Conference*, Jan. 1988, Art. no. 362.
- [18] I. Demirdžić and M. Perić, "Finite volume method for prediction of fluid flow in arbitrarily shaped domains with moving boundaries," *International Journal for Numerical Methods in Fluids*, vol. 10, no. 7, pp. 771–790, 1990, <https://doi.org/10.1002/flid.1650100705>.
- [19] A. Kovacevic, "Boundary adaptation in grid generation for CFD analysis of screw compressors," *International Journal for Numerical Methods in Engineering*, vol. 64, no. 3, pp. 401–426, 2005, <https://doi.org/10.1002/nme.1376>.
- [20] B. G. S. Prasad, "CFD for Positive Displacement Compressors," in *International Compressor Engineering Conference*, 2004, Art. no. 1689.
- [21] I. Malael and M. Sima, "Numerical Investigation of a Screw Compressor Performance," *TURBO*, vol. 4, no. 2, pp. 25–30, Dec. 2017.
- [22] M. Ion, D. Valeriu, G. B. George, P. Ionut, and Ș. A. Ștefan, "Numerical Efficiency Evaluation of a High Pressure Ratio Screw Compressor," in *2018 5th International Conference on Mathematics and Computers in Sciences and Industry (MCSI)*, Corfu, Greece, Dec. 2018, <https://doi.org/10.1109/MCSI.2018.00009>.
- [23] S. Tomescu and I. O. Bucur, "Numerical Investigation of Oil Gas Separation with the Use of VOF CFD," *Engineering, Technology & Applied Science Research*, vol. 11, no. 6, pp. 7841–7845, Dec. 2021, <https://doi.org/10.48084/etasr.4446>.
- [24] S. Tomescu, M. Enache, N. Visan, and F. Florean, "Experimental Measurements Using Shadowgraph System on the Screw Compressor," *UPB Scientific Bulletin, Series D*, vol. 84, no. 1, pp. 77–86, 2022.
- [25] S. Tomescu, V. Petrescu, A. Serban, and S. Voicu, "Energy Efficiency of an Oil Injected Screw Compressor Operating at Various Discharge Pressures," in *2021 10th International Conference on Energy and Environment (CIEM)*, Bucharest, Romania, Jul. 2021, <https://doi.org/10.1109/CIEM52821.2021.9614754>.
- [26] N. P. Mahmoud and A. Zabihi, "Numerical Simulation of a Single-Phase Flow Through Fractures with Permeable, Porous and Non-Ductile Walls," *Engineering, Technology & Applied Science Research*, vol. 7, no. 5, pp. 2041–2046, Oct. 2017, <https://doi.org/10.48084/etasr.1448>.
- [27] F. Chen *et al.*, "Development and coalescence mechanism of an improved filter cartridge for oil mist separators," *Chemical Engineering Research and Design*, vol. 187, pp. 306–318, Nov. 2022, <https://doi.org/10.1016/j.cherd.2022.09.008>.
- [28] A. Spille and J. Hesse, "Structured meshes and reliable CFD simulations: TwinMesh for positive displacement machines," in *International VDI Conference Screw Machines*, Dortmund, Germany, Sep. 2014.
- [29] I. Malael, I. O. Bucur, and C. Slujitoru, "Numerical Investigation of the Minimum Gap Impact on the Screw Compressor Efficiency," *IOP Conference Series: Materials Science and Engineering*, vol. 916, no. 1, Jun. 2020, Art. no. 012057, <https://doi.org/10.1088/1757-899X/916/1/012057>.
- [30] R. Andres, J. Hesse, and A. Spille, "Investigation of radial gap size change under load and the impact on performance for a twin screw compressor using numerical simulation," *IOP Conference Series: Materials Science and Engineering*, vol. 1267, no. 1, Aug. 2022, Art. no. 012007, <https://doi.org/10.1088/1757-899X/1267/1/012007>.
- [31] "TwinMesh | Reliable CFD analysis of rotary pd machines," *TwinMesh*. <https://www.twinmesh.com/>.
- [32] R. Andres, J. Hesse, F. Hetze, and D. Low, "Cfd simulation of a two stage twin screw compressor including leakage flows and comparison with experimental data," *IOP Conference Series: Materials Science and Engineering*, vol. 425, no. 1, Jun. 2018, Art. no. 012018, <https://doi.org/10.1088/1757-899X/425/1/012018>.
- [33] S. Rane, A. Kovačević, and N. Stošić, "Analytical Grid Generation for accurate representation of clearances in CFD for Screw Machines," *IOP Conference Series: Materials Science and Engineering*, vol. 90, no. 1, Apr. 2015, Art. no. 012008, <https://doi.org/10.1088/1757-899X/90/1/012008>.
- [34] S. Rane, A. Kovacevic, N. Stosic, and M. Kethidi, "Grid deformation strategies for CFD analysis of screw compressors," *International Journal of Refrigeration*, vol. 36, no. 7, pp. 1883–1893, Nov. 2013, <https://doi.org/10.1016/j.ijrefrig.2013.04.008>.
- [35] L. Olarasu, M. Stoicescu, I. Malureanu, and I. Onutu, "Considerations for Using a Hydraulic Fracturing Fluid for Breaking Crude Oil Emulsion from Reservoir," *Revista de Chimie*, vol. 69, no. 6, pp. 1498–1500, Jul. 2018, <https://doi.org/10.37358/RC.18.6.6354>.
- [36] "Oil-injected screw compressors for natural gas, air, CO₂, N₂ and other," *COMOTI - Romanian Research and Development Institute for Gas Turbines*. <http://www.comoti.ro/en/Comprosoare-cu-surub.htm>.

AUTHORS PROFILE

Ion Malael was born in 1985. Member of RRDI COMOTI since 2009, PhD in Aerospace Engineering, 2014, Master in Software in Aerospace Engineering, 2011, Aviation Engineer – Aerospace Constructions, Aerospace Engineering Faculty at UPB – 2009. Experience in CFD (ANSYS CFX, Fluent), CAD design (CATIA V5, Solidworks, AutoCAD), and wind turbine experimentation. Most of the projects in which he participated were in the field of bladed machines, the main scientific achievements focusing on improving their performance. He has published over 50 scientific articles in conferences and specialized journals. From 2009 until now he has been involved in over 30 national (partnerships, Nucleu, Innovation check, STAR) and international (FP7, Clean Sky, H2020) research projects. He reviews around 20 papers per year.

Aurel-Valentin Petrescu was born in 1986. Member of RRDI COMOTI since 2009, PhD Student, Master in Mechatronics 2011, Mechanical Engineering Faculty at UPB 2009, Experienced in CAD design (CATIA V5, Solidworks, Solid Edge, AutoCAD) and screw compressor experimentation. Most of the project he was involved in are in the field of screw compressor and compression packages design. He has published over 20 scientific articles in conferences and specialized journals. From 2009 until now he has been involved in over 25 national research projects (partnership, Nucleu). He is the technical manager of the screw compressor test bench.